

CIRCUIT PENDANT

CIR-24P (24")

CAUTION

TURN OFF THE MAIN POWER AT THE CIRCUIT BREAKER BEFORE INSTALLING THE FIXTURE IN ORDER TO PREVENT POSSIBLE SHOCK

IF YOU ARE UNFAMILIAR WITH PROPER ELECTRICAL WIRING CONNECTIONS OBTAIN THE SERVICES OF A QUALIFIED ELECTRICIAN

GENERAL

- Read all instructions carefully for safe operation and installation.
- All electrical connections must be in accordance with local and national electrical code (N.E.C) standards.
- Remove the fixture and the mounting package from the box and make sure that no parts are missing by referencing the illustrations on the installation instruction. Please contact Blackjack Lighting if any parts are missing or damaged.
- This product is suitable for damp locations.

INSTALLATION**PREPARATION**

1. Remove the fixture from its box.
2. Remove the ceiling plate(10) from the canopy cover(11) by loosening the three thumbscrews(12).

MOUNTING

3. Pull the supply wires(2&4) and the house ground wire(6) out of the outlet box(1) and thread them through the large center hole in the ceiling plate(10). Attach the ceiling plate(10) to the outlet box(1) by using the two mounting screws(9).

ELECTRICAL CONNECTIONS

4. Using the wire connectors(8), connect the white supply wire(2) to the white fixture wire(3); connect the black supply wire(4) to the black fixture wire(5); and connect the house ground wire(6) to the fixture ground wire(7). Tuck all of the wires back into the outlet box(1).

FINAL ASSEMBLY

5. Adjust the three suspension cables to the appropriate length by either pushing the individual cables up into the adjustable gripper(13) or by pushing the small barrel on the bottom of the gripper(13) upward. This will release the cable tension and allow the suspended cable to increase in length.
6. Secure the canopy cover(11) to the ceiling plate(10) by tightening the three thumbscrews (12).
7. Once the canopy cover(11) is in place, use the adjustable grippers(13) to fine tune the fixture suspension cable lengths so that the fixture is level and the three cables are even in length.

DIMMING

- Fixture Dimming Type: TRIAC, ELV, or 0-10V dimmable.
- For recommended dimmers see <https://www.blackjacklighting.com/dimming-information>

HARDWARE



Wire Connectors (#8)
[3 Included]



Mounting Screws (#9)
[2 Included]



Thumb screws (#12)
[3 Included]

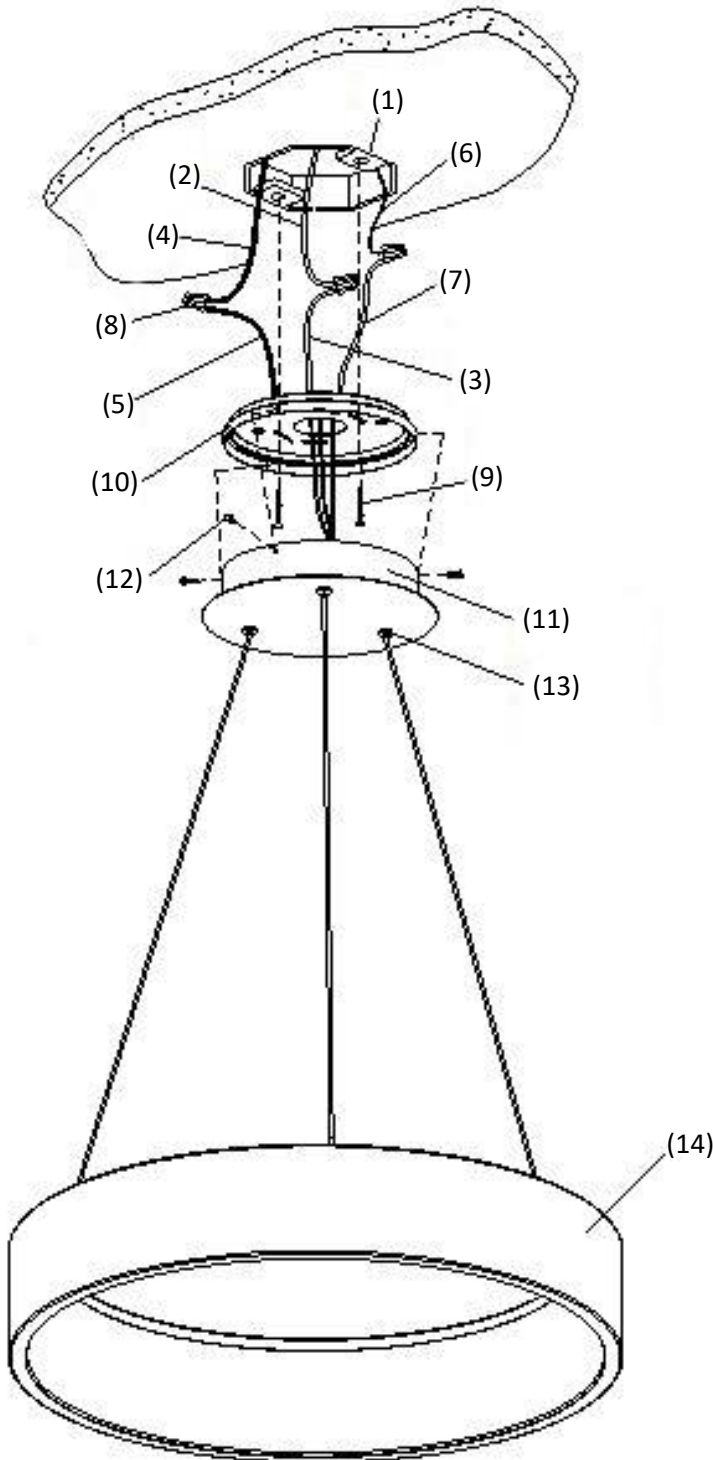

1. OUTLET BOX (by others)
2. WHITE SUPPLY WIRE
3. WHITE FIXTURE WIRE
4. BLACK SUPPLY WIRE
5. BLACK FIXTURE WIRE
6. HOUSE GROUND WIRE
7. FIXTURE GROUND WIRE
8. WIRE CONNECTORS
9. MOUNTING SCREWS
10. BACK PANEL
11. DECORATIVE PAN
12. THUMBSCREW
13. GRIPPER
14. FIXTURE BODY