

CIRCUIT PENDANT

CIR-43P (43")

CAUTION

TURN OFF THE MAIN POWER AT THE CIRCUIT BREAKER BEFORE INSTALLING THE FIXTURE IN ORDER TO PREVENT POSSIBLE SHOCK

IF YOU ARE UNFAMILIAR WITH PROPER ELECTRICAL WIRING CONNECTIONS OBTAIN THE SERVICES OF A QUALIFIED ELECTRICIAN

GENERAL

- Read all instructions carefully for safe operation and installation.
- All electrical connections must be in accordance with local and national electrical code (N.E.C) standards.
- Remove the fixture and the mounting package from the box and make sure that no parts are missing by referencing the illustrations on the installation instruction. Please contact Blackjack Lighting if any parts are missing or damaged.
- This product is suitable for damp locations.

INSTALLATION**PREPARATION**

1. Remove the fixture from its box.
2. Remove the back panel(10) from the decorative pan(11) by loosening the three thumbscrews(12).

MOUNTING

3. Pull the supply wires(2&4) and the house ground wire(6) out of the outlet box(1). Attach the back panel(10) to the outlet box(1) by using the two mounting screws(9).

ELECTRICAL CONNECTIONS

4. Using the wire connectors(8), connect the white supply wire(2) to the white fixture wire(3); connect the black supply wire(4) to the black fixture wire(5); and connect the house ground wire(6) to the fixture ground wire(7).
5. Adjust the four suspension cables to the appropriate length by either pushing the individual wires up into the adjustable gripper(13) or by pushing the small barrel upward (located on the bottom of the adjustable gripper). This will release the wire tension and allow the suspended wire to increase in length.
6. To secure the decorative pan(11) to the back panel(10) align the holes in the decorative pan(11) with the holes in the back panel(10). Then insert and tighten the three thumbscrews(12).

FINAL ASSEMBLY

7. Once the canopy is in place, use the adjustable grippers(13) to fine tune the fixture suspension cable lengths so that the fixture is level and the four wires are even in length.

DIMMING

- Fixture Dimming Type: TRIAC, ELV, or 0 - 10V dimmable
- For recommended dimmers see <https://www.blackjacklighting.com/dimming-information>

HARDWARE



Wire Connectors (#8)
[3 Included]



Mounting Screws (#9)
[2 Included]



Thumb screws (#12)
[3 Included]

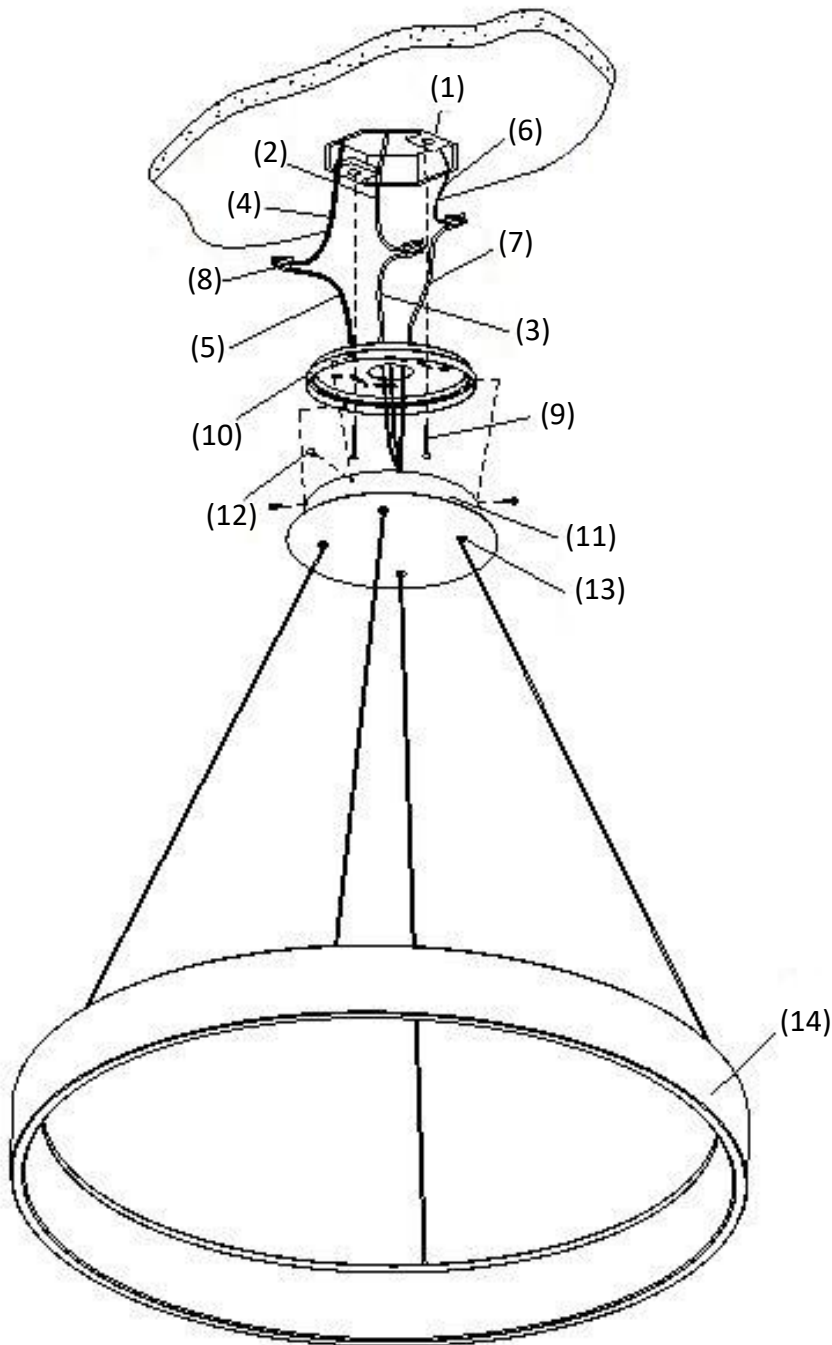

1. OUTLET BOX (by others)
2. WHITE SUPPLY WIRE
3. WHITE FIXTURE WIRE
4. BLACK SUPPLY WIRE
5. BLACK FIXTURE WIRE
6. HOUSE GROUND WIRE
7. FIXTURE GROUND WIRE
8. WIRE CONNECTORS
9. MOUNTING SCREWS
10. BACK PANEL
11. DECORATIVE PAN
12. THUMBSCREW
13. GRIPPER
14. FIXTURE BODY