

REAR

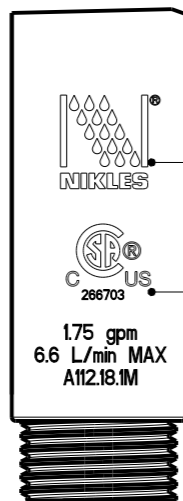

FRONT



FRONT

SCALA 1:1

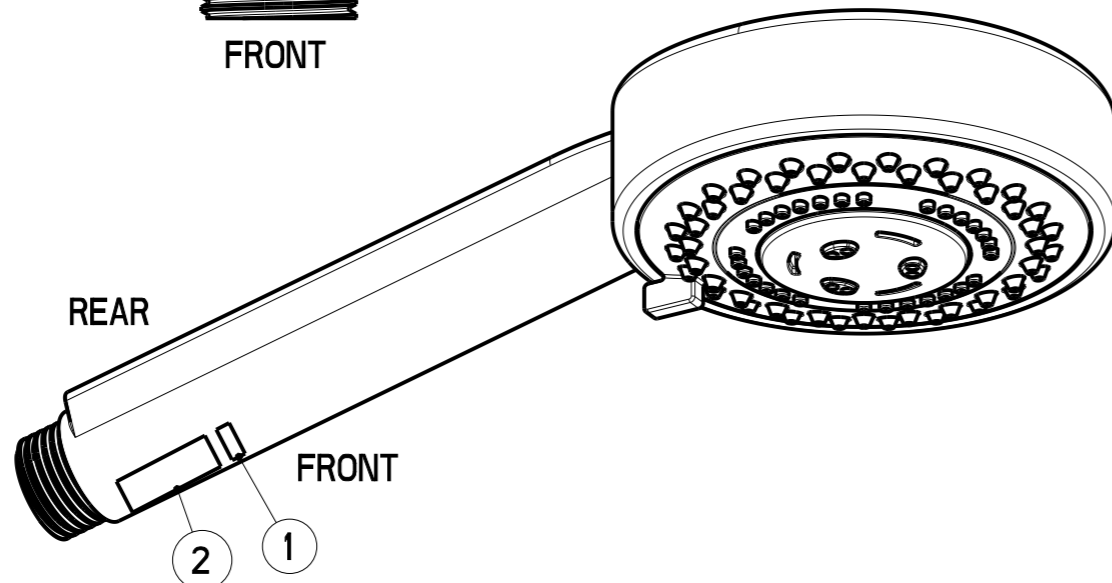

REAR

FRONT

2 1

229  
9"

37  
1.45"

23  
0.9"

Ø 95  
Ø 3.74"

NIKLES CODE	COSTUMER CODE	COMPONENTS	xy	FINISH SURFACE	***	COSTUMER REFERENCE
D1205QM-1.75/IA	-	1.1 - 2.1	05	CHROME	/IA	in plastic bag
D1234QM-1.75/IA	-	1.1 - 2.1	34	BRUSHED NICKEL	/IA	in plastic bag
D1225QM-1.75/IA	-	1.1 - 2.1	25	POLISHED NICKEL	/IA	in plastic bag
D1205QM-1.75N/US	-	1.2 - 2.1	05	CHROME	N/US	In Nikles box
D1234QM-1.75N/US	-	1.2 - 2.1	34	BRUSHED NICKEL	N/US	in Nikles box
D1225QM-1.75N/US	-	1.2 - 2.1	25	POLISHED NICKEL	N/US	in Nikles box
D1205QM-1.75B/US	-	1.1 - 2.1	05	CHROME	B/US	in white box
D1234QM-1.75B/US	-	1.1 - 2.1	34	BRUSHED NICKEL	B/US	in white box
D1225QM-1.75B/US	-	1.1 - 2.1	25	POLISHED NICKEL	B/US	in white box
D1205QM-1.75/AF	-	1.3 - 2.2	05	CHROME	/AF	in white box
D1234QM-1.75/AF	-	1.3 - 2.2	34	BRUSHED NICKEL	/AF	in white box
D1225QM-1.75/AF	-	1.3 - 2.2	25	POLISHED NICKEL	/AF	in white box

2.1	Logo CSA DOE 1.75 gpm	09 0156
2	Logo APPROVAL	
1.3	Logo e&b	09 0172
1.2	Logo NIKLES	09 0000
1.1	No Logo	
1	Logo COSTUMER	
POS.	DENOMINAZIONE / DESCRIPTION	DISEGNO / DRAWING

01	Updating with e&b logo	28/05/18	Beschi F.	50 1145.00
N°	MODIFICA - MODIFICATION	Data - Date	Firma - Sign	Sostituisce - Replace
DENOMINAZIONE - DESCRIPTION		SPECIFICHE - NOTE		
FRESH 95 3S 1.75 GPM - US		<ul style="list-style-type: none"> <li>- Flow Limiter + Not Return 1.75 GPM - NIKLES BCF-D15-1.75</li> <li>- Star Washer</li> <li>- Marking Applied by Laser Etching</li> </ul>		
DISEGNO DRAWING	50 1145.01.00.00	CODICE ITEM D12xyQM-1.75***		
 NIKLES NIKLES TEC ITALIA s.r.l. Z.I. Cornali via A. Volta n° 2 25013 Carpenedolo - BRESCIA Telefono 030-9698716 Fax 030-9966505 www.nikles.com	DISEGNATO DRAW	CONTROLLATO CHECK	PESO (g) WEIGHT (g)	
	Data - Date	10/11/17	10/11/17	SCALA SCALE
Firma - Sign	Beschi F.	Turrini A.		
DIR./FILE 50_1145_SHOWER_FRESH_1.75_CSA				
UFFICIO TECNICO NIKLES TEC ITALIA USO RISERVATO CONFIDENZIALE VIETATA LA RIPRODUZIONE COPYRIGHT NIKLES TEC ITALIA				